

Extrusion

Hot work tool steels
with special suitability
for extrusion



**Deutsche
Edelstahlwerke**

Extrusion

Extrusion is a solid forming process, in which a heated billet is transformed into a profile under pressure.

In direct extrusion the raw ingot is heated to forming temperature and pressure is applied onto the ingot via the extrusion ram, whereupon the material is pressed through the forming die. In indirect extrusion, the die, which is firmly connected to the extrusion punch, is pressed through the tightly closed recipient, eliminating the relative movement between the workpiece and the recipient wall, which is a source of wear in direct extrusion. Either way, extrusion allows the production of a wide variety

of solid and hollow profiles which require the least amount of reworking.

Although almost any formable material can be processed, extrusion is used primarily for light metals, as their low forming temperature and deformation resistance allow even most complex profiles.

Depending on the material to be processed, the process parameters, as well as the degree of forming and the geometry of the end product, different challenges arise with regard to the lifetime of the tool and the entire equipment of the assembly.



Deutsche Edelstahlwerke provides proven hot work tool steels for a long service life, adjusted to the individual main requirement.

For the tools on the outlet side of the system, which are not in direct contact with the hot metal, steels with high strength and good toughness are recommended: Thermodur® 2329 and Thermodur® 2714.

Stem, dummy block, liner and ejector are exposed to high temperature, high pressure and wear, all of which require steels of excellent properties regarding high tempering resistance, hot

toughness and hot wear resistance. That is the reason for the use of high alloyed hot work tool steels for these components. The die as the central part of the system, deserves special attention regarding the choice of steel.

The more sophisticated the design the higher the demand on the tool: apart from wear and heat, delicate designs may require excellent toughness properties even in the core of larger dies. While DEW's standard metallurgical EFS (extra fine structure) fulfills most requirements, increasing dimensions and complexity of the die might require the use of remelted (Superclean) material.

Our hot work tool steels

Brandname	Chemical composition [%]						
	C	Si	Mn	Cr	Mo	V	Ni
Thermodur® 2329	0.45	0.70	0.80	1.80	0.30	0.20	0.60
Thermodur® 2714	0.56	0.30	0.80	1.10	0.50	0.10	1.70
Thermodur® 2343 EFS	0.37	1.00	0.30	5.00	1.30	0.45	
Thermodur® 2344 EFS	0.40	1.00	0.30	5.30	1.30	1.00	
Thermodur® 2367 EFS	0.37	0.30	0.40	5.00	3.00	0.60	
Thermodur® XLL EFS	0.35	0.30	0.30	5.00	1.90	0.70	
Thermodur® E 38 K Superclean	0.35	0.30	0.30	5.00	1.35	0.45	
Thermodur® E 40 K Superclean	0.35	0.30	0.30	5.00	1.90	0.70	

Steels for high requirements

Thermodur® 2329 and Thermodur® 2714

are universally applicable tool steels. Due to their metallurgical properties both steels exhibit very good core strength and toughness even at larger dimensions, but limited high temperature properties. This results in applications as support tools, backer, and bolster.

Thermodur® 2343 EFS and Thermodur® 2344 EFS

are widely used for hot work applications. Due to their high wear resistance and toughness at elevated temperatures, these steels cover most of the requirements exerted on the tools in extrusion processes.

Thermodur® 2367 EFS

compared to Thermodur® 2343 and 2344, the higher content of alloying elements makes Thermodur® 2367 EFS particularly suitable for applications, where hot wear resistance is recognized as a primary criterion for steel selection.

Thermodur® XLL EFS

this high-performance steel is a further development of the well-known hot-work tool steels. Due to its adapted analysis, this steel has similar good hot wear resistance as



provided by Alumasa, BRA

Thermodur® 2367 EFS, but significantly improved toughness to the level of the lower alloyed Thermodur® 2344 EFS.

In order to improve the homogeneity of the steels, Deutsche Edelstahlwerke dispose of numerous remelting units. Larger dimensions and complex tools require high demands on toughness and homogeneity over the entire cross-section. For this purpose the use of our premium Superclean grades (Electro Slag Remelted) is recommendable.

High Performance steel grades

Thermodur® E 38 K Superclean

As a premium remelted hot work tool steel with outstanding toughness compared to all existing hot work tool steels, Thermodur® E 38 K Superclean is recommended especially for large and high complex dies.

Thermodur® E 40 K Superclean

is due to its perfectly coordinated property profile our premium grade for extrusion dies with highest demands. The excellent combination of highest toughness and best hot wear resistance leads to longest tool lifetime in extrusion processes. With its outstanding isotropy of mechanical technological properties, Thermodur® E40 K Superclean is the perfect solution even for medium sized and large dies.

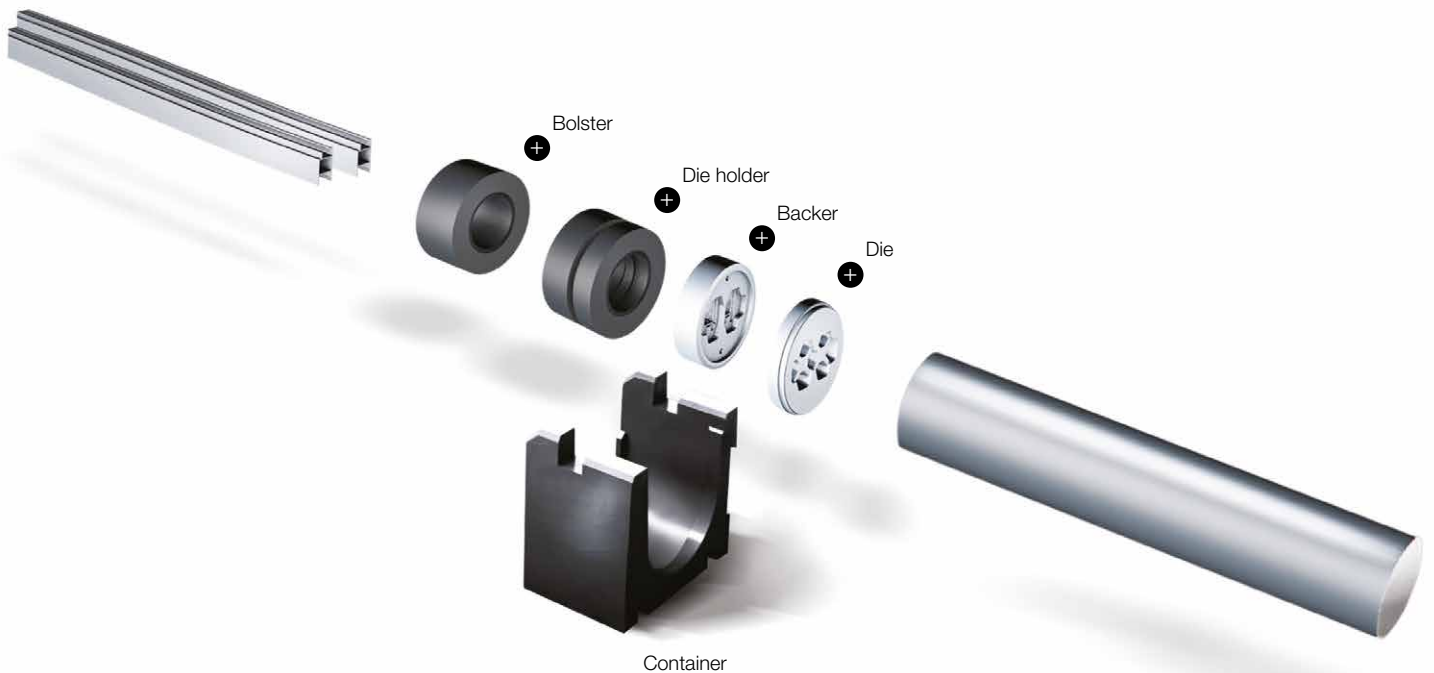

General note (liability)

Not liable for printing errors, omissions and/or changes. All statements regarding the properties and/or utilization of the materials or products mentioned are for purpose of description only. Product specific data sheet have priority over the information provided in this brochure. The desired performance characteristics are binding only if exclusively agreed upon in writing at the conclusion of the contract.

Decision tree

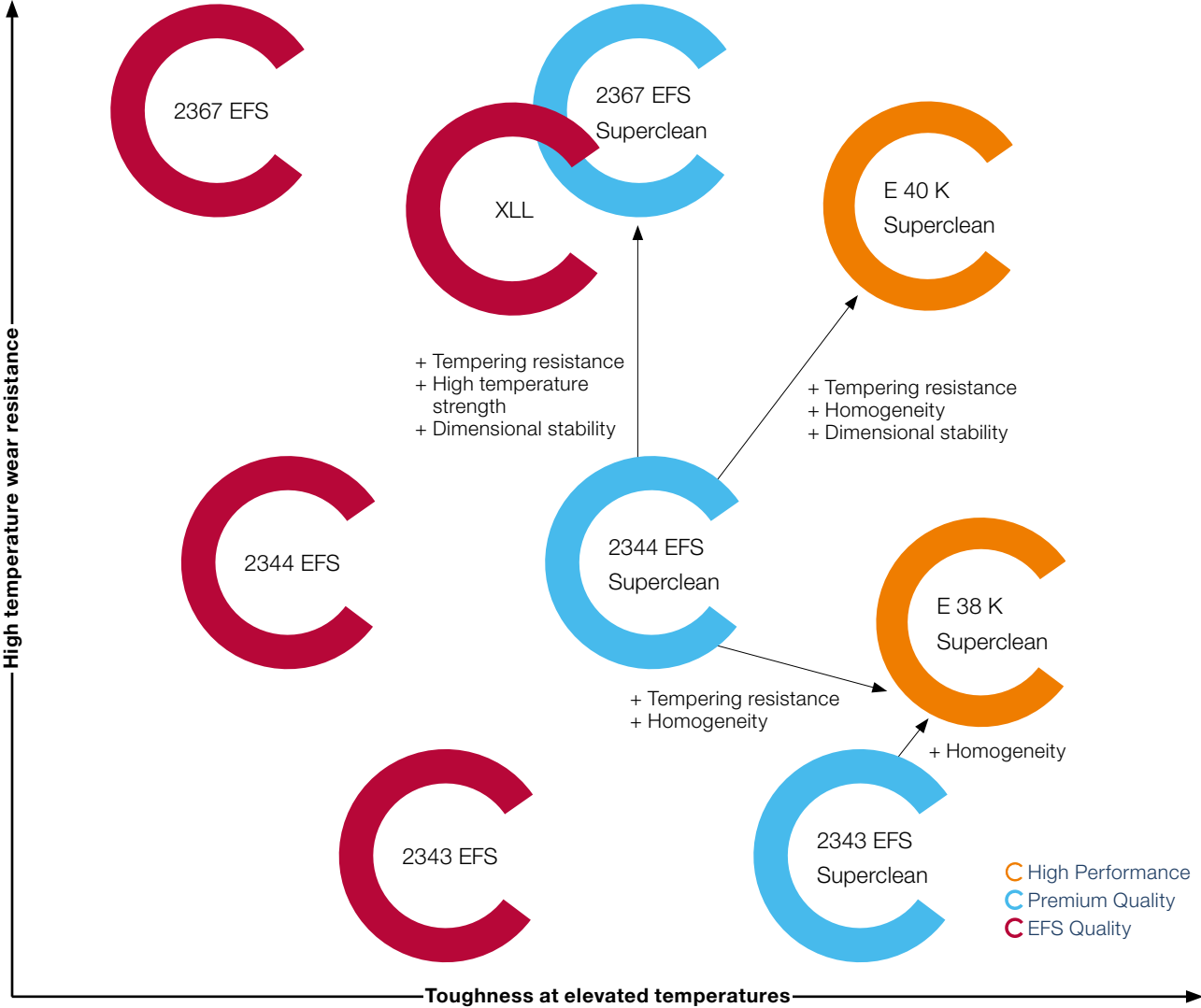

Property Comparison

Brandname	Tempering resistance	Wear resistance	Toughness	Dimensional stability
Thermodur® 2714	0	0	+++	+
Thermodur® 2343 EFS	++	+	++	++
Thermodur® 2344 EFS	++	++	+	++
Thermodur® 2367 EFS	++++	++++	+	++++
Thermodur® XLL EFS	+++	+++	++	++++
Thermodur® E 38 K Superclean	++	+	++++	++
Thermodur® E 40 K Superclean	+++	+++	+++	++++



**Deutsche Edelstahlwerke
Specialty Steel GmbH & Co. KG**

info@dew-stahl.com

dew-stahl.com

Member of Swiss Steel Group

swisssteel-group.com